

MAGNETIC DRIVE SEAL-LESS PUMPS



**Pumpen
Rührwerke**

4153 Reinach BL

Duggingerstrasse 2

Telefon +41(0)61 711 66 36

Telefax +41(0)61 711 68 06

e-mail: alowag@alowag.ch

internet://www.alowag.ch

Gruppo Aturia



MAGNETIC DRIVE SEAL-LESS PUMPS

Since 2005, **ROTOS DIVISION of GRUPPO ATURIA** has developed this extensive program of pumps for industry with a new complete line of SEAL-LESS MAGNETIC DRIVE PUMPS.

High qualified technical office and high specialized people, with more than 20 years experience, has designed and continues to develop 100% of the products, from hydraulic ends to proprietary magnetic couplings.

ROTOS, a division of **GRUPPO ATURIA**, has specialized in the application, engineering and distribution of *technically advanced, hermetically sealed, magnetic drive pumps.*

ROTOS seal-less Mag-Drive pumps are now available in 18 different designs with over 250 basic models. This vast pump range allows our Engineering department to meet your exact process requirements.

All **ROTOS** seal-less pumps and equipments are engineered to comply with latest Industrial Pump Standard:

- **ISO 2858** Seal-less centrifugal magnetic drive pumps
- **API 685** Seal-less MDP pumps for Petroleum Industry

In addition **ROTOS** produces custom engineered models for the most demanding applications:

- **STM** Seal-less regenerative turbine magnetic drive alloy pumps
- **PTM** Seal-less regenerative turbine magnetic drive non-metallic pumps
- **SVM** Seal-less rotary vane magnetic drive alloy pumps
- **PCM** Seal-less centrifugal magnetic drive non-metallic pumps
- **SDM** Seal-less centrifugal magnetic drive alloy pumps

ROTOS pumps are serviced through an International network of factory trained stocking Distributors providing Engineering, application assistance, system design, and in the field troubleshooting world-wide.

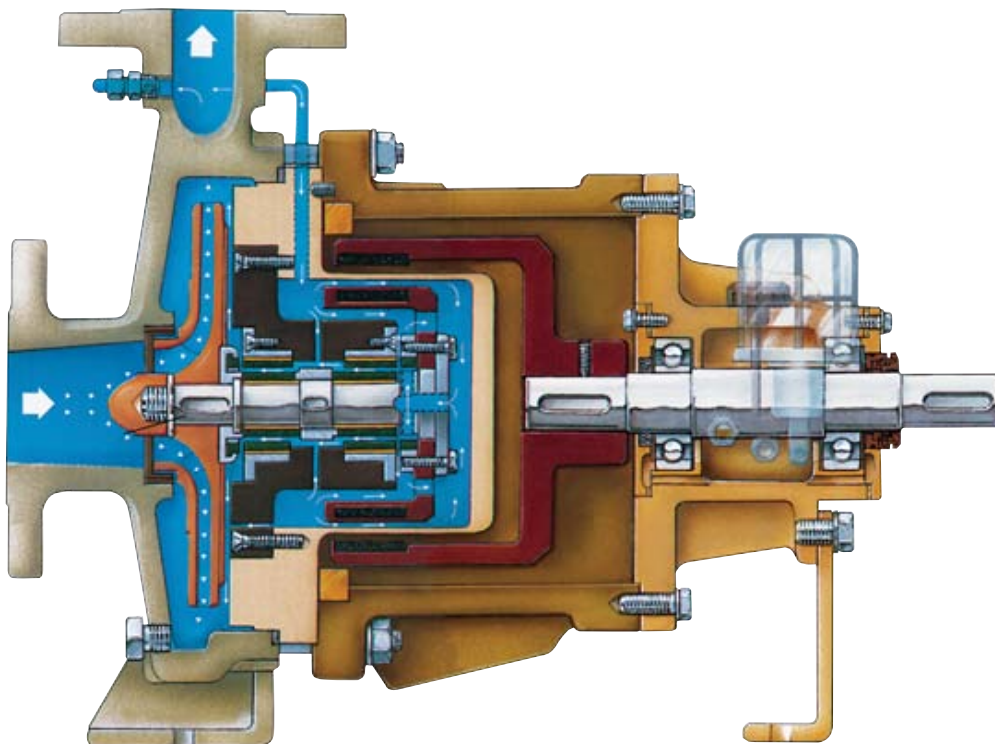

CENTRIFUGAL PUMPS

NDM Series

Pumps of NDM series are single stage centrifugal magnetic drive pumps in accordance to ISO 2858. Foot mounting, single volute casing with flanged end suction and top discharge. The impeller is hydraulically and dynamically balanced and designed to achieve high efficiency and low N.P.S.H. values. Shaft supported by oil lubricated ball bearings. Close coupled available. Performance and dimensions of the NDM pump line are in accordance with ISO 2858 standards.

COBALT-SAMARIUM MAGNETS STANDARD
 SYNCHRONOUS MAGNET COUPLINGS ONLY, NO SLIPPING
 SILICON CARBIDE BEARINGS STANDARD - CARBON OPTION

All pumps of the NDM line have been designed to a modular concept so as to reduce the stock of spares with the advantage of low stocking costs. The NDM line is back-pull-out design, therefore when the pump unit is equipped with a spacer type coupling, the complete rotor can be removed from pump casing without disturbing piping and motor.

All pumps are manufactured in accordance with the current CE-Standard
 **** Explosion proof models according to ATEX directive, category II are also available. ****

Discharge nozzles	32 up to 100	
Poles	2	4
Capacity [m ³ /h]	8-200	3-100
Head [m]	up to 90	up to 25
Max. Pressure [Bar]	16	
Max. Temper. (°C)	300	

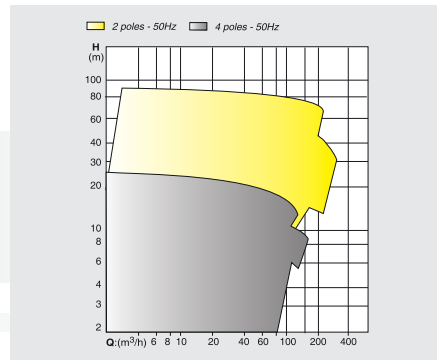

SECTIONAL DRAWING

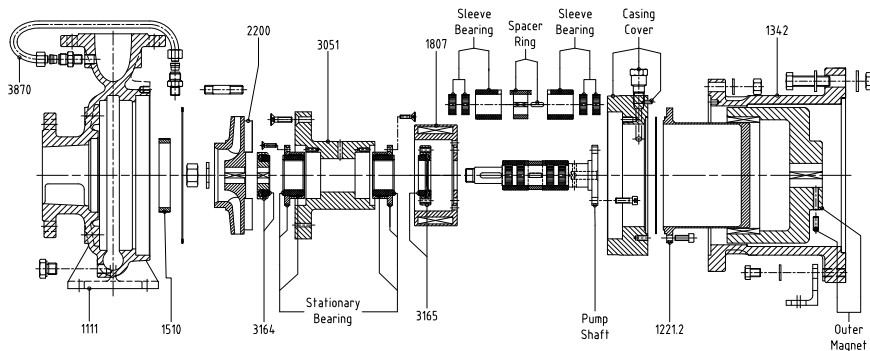

FEATURES

- Single stage centrifugal pumps
- Performances and Dimensions: ISO 2858
- Models:
 - Range 1°: 5x3x12 up to 8x6x16
 - Range 2°: 5x3x25 up to 12x10x20

MATERIALS

- Stainless Steel AISI 316L with cast components CF8M
- On request Incoloy 825 and Hastelloy C

APPLICATIONS

- Chemical and Petrochemical plants
- Oil Refinery
- Pharmaceutical
- Heat transfer oil
- Hot water
- Food processing

ref	DESCRIPTION	MATERIAL
1111	Pump Casing	ASTM CF8M
1221.2	Rear Casing	AISI 316L / HC276
1342	Bracket	G25
1510	Casing Wear Ring	AISI 316L
	Outer Magnet	Neodym / Steel
1807	Inner Magnet	AISI 316L / CoSm
	Pump Shaft	Stainless Steel
2200	Impeller	ASTM CF8M
	Sleeve Bearing	AISI 316L + SiC
2905.3	Impeller Nut Lockwasher	AISI 316L
2912	Impeller Nut	AISI 316L
3051	Pump Shaft Housing	AISI 316L
3164	Rear Thrust Bearing	SiC / AISI 316L
3165	Front Thrust Bearing	SiC / AISI 316L
	Stationary Bearing	AISI 316L + SiC
3870	Flushing Pipe	AISI 316L

CENTRIFUGAL PUMPS

PCM / PCM-SP Series

Pumps of the PCM series are single stage centrifugal magnetic drive pumps. Pump casings with heavy wall thickness, machined from solid blocks of PP and PVDF. No metallic parts in contact with the pumped liquid. PCM and PCM-SP magnetically coupled are available with compact design, close coupled for standard, off the shelf, IEC and NEMA motors. All pumps are equipped with high purity 99,7% Alumina Oxide shaft and thrust bearings, option Sintered Silicon Carbide. Sleeve bearings are made of PTFEC for long life and excellent chemical resistance, option Silicon Carbide. O-rings in EPDM, VITON or FEP. Self priming models, series PCM-SP, are capable to lift corrosive liquid up to 5 mt without the need of a foot valve and with empty suction pipe. Ideally for underground tanks transferring and truck unloading.

All pumps are manufactured in accordance with the current CE-Standard
 **** Explosion proof models according to ATEX directive, category II are also available. ****

Discharge nozzles	32 up to 80	
Poles	2	4
Capacity [m ³ /h]	1-140	1-80
Head [m]	4 - 45	1 - 11
Max. Pressure (Bar)	10	
Max. Temper. (°C)	100	

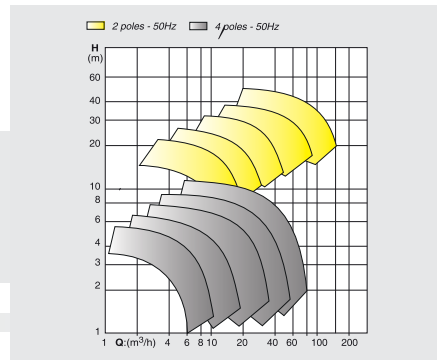

FEATURES

- Single stage centrifugal pumps
- Performances and Dimensions: our standard PN 10
- Flanged nozzles
- Models: 3 x12 up to 8x18
- High Flow
- No metal in contact with pumped liquid
- Machined from solid block

MATERIALS

- Techno-polymers: PP- PVDF

APPLICATIONS

- Chemical plants
- Pharmaceutical
- Food processing
- Laboratories
- Transfer of solvents and alkalis
- Refrigerants

SECTIONAL DRAWING

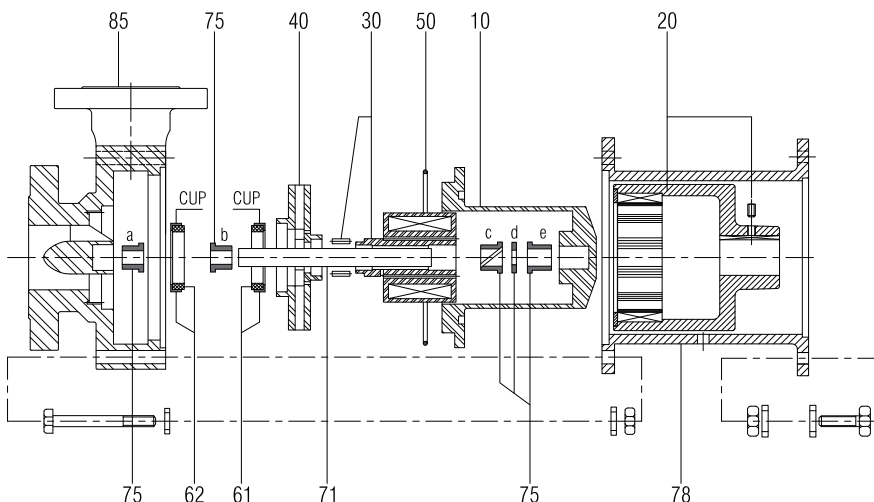

ref	DESCRIPTION	MATERIAL
10	Rear Casing	PP or PVDF
20	Ext. Magnet	Neodym./Steel
30	Int. Magnet	PP/Neodym.
40	Impeller	PP or PVDF
50	O-Ring 4525	EPDM or Viton
61	Imp. Front Thr. Brg+Cup	PTFEC
62	Casing Thrust Brg + Cup	Ceramic
71	Shaft	Ceramic
75	Bearings	PTFEC
78	Bracket	Cast Iron
85	Pump Head	PP

TURBINE PUMPS

PTM / PTM-SP Series

PTM regenerative turbine pumps avoid oversized centrifugals with excessive by-pass and power requirements. Exotic alloy gear pumps designs, often result in rapid corrosion and wear, leading to costly replacements. PTM non-metallic turbine designs have excellent chemical resistance and extremely low wearing characteristics. Variation in head have minimal effect on the flow of a turbine pump. Also, turbine pumps can be throttle to a required duty point without by-passing.

Exclusive solid machined casing made of PP or PVDF.

Oversized, high purity ceramic shaft, Silicon Carbide option.

Self-balancing impeller eliminates thrust bearing wear.

Handles up to 20% entrained gas.

Separate impeller minimizes maintenance costs.

Self priming models, series PTM-SP, are capable to lift corrosive liquid up to 5 mt without the need of a foot valve and with empty suction pipe. Ideally for underground tanks transferring and truck unloading.

All pumps are manufactured in accordance with the current CE-Standard

**** Explosion proof models according to ATEX directive, category II are also available. *****

Discharge nozzles	3/4" up to 1 1/2"
Poles	2
Capacity [m ³ /h]	up to 13
Head [m]	up to 55
Max. Pressure (Bar)	10
Max. Temper. (°C)	100

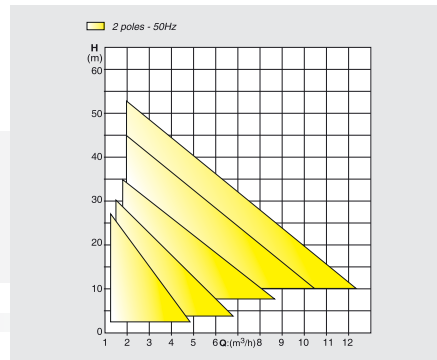

SECTIONAL DRAWING

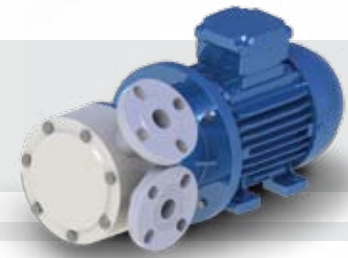
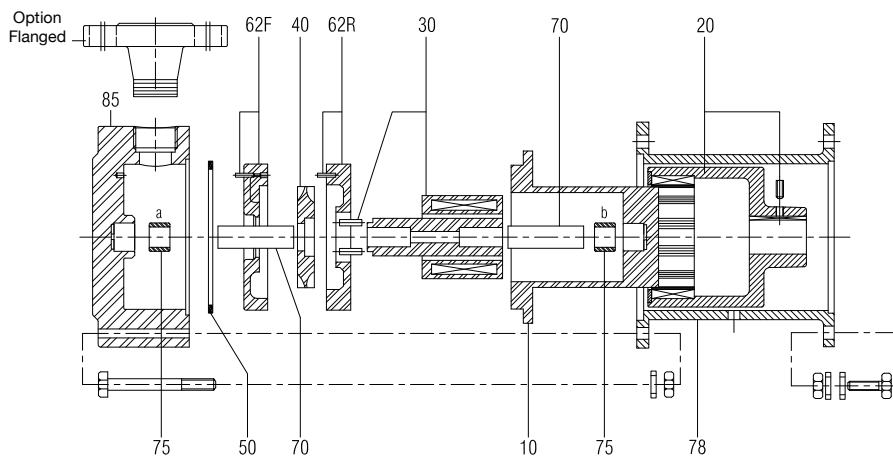

FEATURES

- Single stage regenerative turbine pumps
- Performances and Dimensions: our standard PN 10
- Models: 2,5x up to 3x10
- Threaded nozzles. option Flanged
- Low Flow, High Head, Entrained gases
- No metal in contact with pumped liquid
- Machined from solid block

MATERIALS

- Techno-polymers: PP - PVDF

APPLICATIONS

- Electroplating and galvanic systems
- Electronics systems
- Laboratories
- Filter units
- Water treatment (Chlorine dioxide)
- Transfer of strong acids

ref	DESCRIPTION	MATERIAL
10	Rear Casing	PP or PVDF
20	Ext. Magnet	Neodym./Steel
30	Int. Magnet	PP or PVDF/Neodym.
40	Impeller	PVDF
50	O-Ring 4362	EPDM or Viton
62F	Front Ring	PP or PVDF
62R	Rear Ring	PP or PVDF
70	Shaft	Ceramic
75	Bearings	PTFEC
78	Bracket	PP
85	Pump Head	PP or PVDF



VANE PUMPS SVM Series



SVM Series Rotary Vane Seal-less Mag-drive pumps are ideally suited for low flow / high head applications. SVM pumps feature self-compensating sliding-vanes which maintain design head and flow capacities for extended operating life. SVM vane pumps are suitable for thin non-lubricating liquids and/or high differential pressure without rapid wear associated with gear mechanisms. SVM pumps are capable of self-priming from a dry start.

No gears to wear or metal to metal contact, low internal slip.
Capable of proportioning with variable speed drives.
Heavy duty casing and rotors machined from wrought alloy bars.
Heavy duty alloy containment shell for added safety.
Replaceable carbon cartridge – low maintenance costs.
Chemically resistant carbon or silicon carbide sleeve bearings.
High torque magnets, suitable for direct starting motors.
Pedestal mounted or close coupled design.

FEATURES

- Positive displacement rotary vane pumps
- Performances and Dimensions: our standard PN 16
- Models: 1x100 up to 2x2000
- Threaded nozzles, option Flanged
- Dry Self Priming
- High Viscosities

MATERIALS

- Stainless Steel AISI 316L fully machined
- On request Incoloy 825 and Hastelloy C

APPLICATIONS

- Chemical and pharmaceutical plants
- Pilot plants & Laboratories
- Injection and sampling systems
- Refrigerants and ammonia recirculation
- Mechanical seal flushing

All pumps are manufactured in accordance with the current CE-Standard
**** Explosion proof models according to ATEX directive, category II are also available. ****

Discharge nozzles	3/8" up to 1
Poles	4
Capacity [m ³ /h]	up to 2,2
Pressure (Bar)	up to 14
Max.Temper. (°C)	300

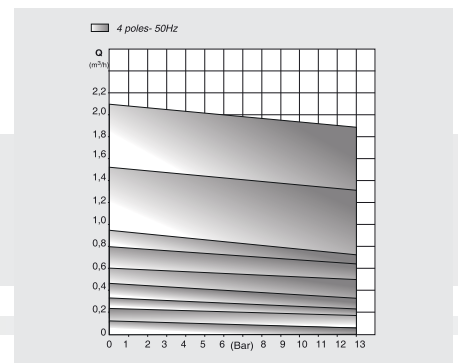

ref	DESCRIPTION	MATERIAL
10	Rear Casing	AISI 316L
20	Ext. Magnet	Neodym./Steel
30	Int. Magnet	AISI 316L/CoSm
51	O-Ring (g+h)	Viton
70	Rotor Shaft	AISI 316L
75	Cartridge Graphite	Graphite / AISI 316L
78	Bracket	Cast Iron
80	Kit Spares	/
85	Pump Body	AISI 316L
86	End Cover	AISI 316L

SECTIONAL DRAWING

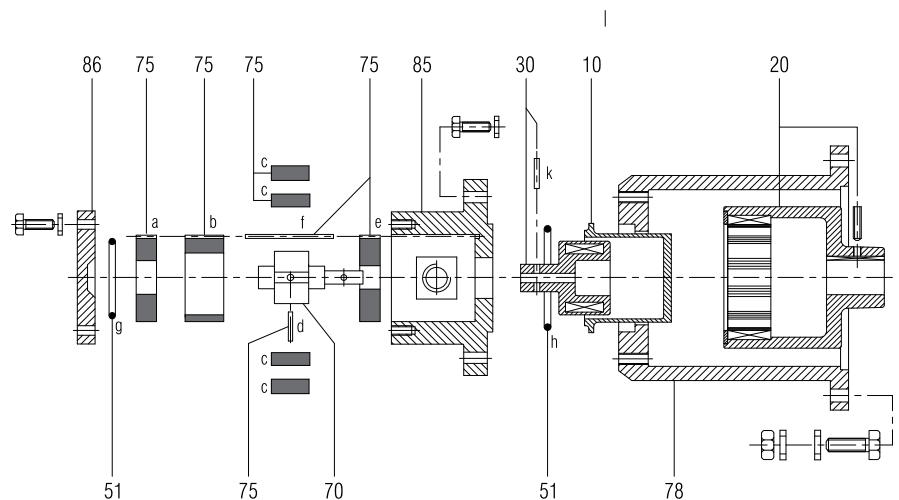



CENTRIFUGAL PUMPS SDM Series



Pumps of SDM series are single stage centrifugal magnetic drive pumps. Simple and compact are robustly built to handle acids, solvents, alkalis, flammable and other aggressive chemicals. Ideally suited for light duty and safe operation ensuring low maintenance cost and long life operation. Powerful magnet couplings Samarium Cobalt ensure secure functioning also with high specific gravity liquids. Quite and efficient, for their versatility and economy, in a vast range of pumping duties, SDM pumps are the appropriate choice for all industries where leak proof applications are required.

All pumps are manufactured in accordance with the current CE-Standard **** Explosion proof models according to ATEX directive, category II are also available. ****

FEATURES

- Single stage centrifugal pumps
- Performances and Dimensions: our standard PN 16
- Models: 2x8 up to 4x14
- Threaded nozzles, option Flanged

MATERIALS

- Stainless Steel AISI 316L with cast components CF8M

APPLICATIONS

- Chemical plants (light duty)
- Pharmaceutical
- Food processing
- Laboratories
- Transfer of solvents and alkalies
- Refrigerants

Discharge nozzles	3/4" up to 1 1/2"
Poles	2
Capacity [m ³ /h]	up to 30
Head [m]	up to 30
Max. Pressure [Bar]	16
Max. Temper. [°C]	200

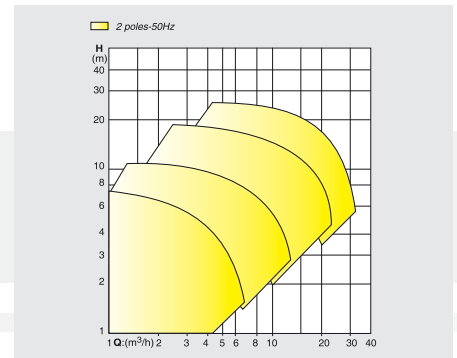

ref	DESCRIPTION	MATERIAL
2	Pump Head	AISI 316L
3	O-Ring 4425	Viton
4	Casing Thr. Bushing	PTFEC or GRAPHITE AISI 316L
5	Shaft	AISI 316L
6	Ring	AISI 316L
7	Impeller	AISI 316L
8	Int. Magnet	AISI 316L/CoSm
9	Sleeve Bearings	PTFEC or GRAPHITE
10	Rear Casing	AISI 316L
11	Ext. Magnet	NeodymJSteel
13	Bracket	Cast Iron

SECTIONAL DRAWING

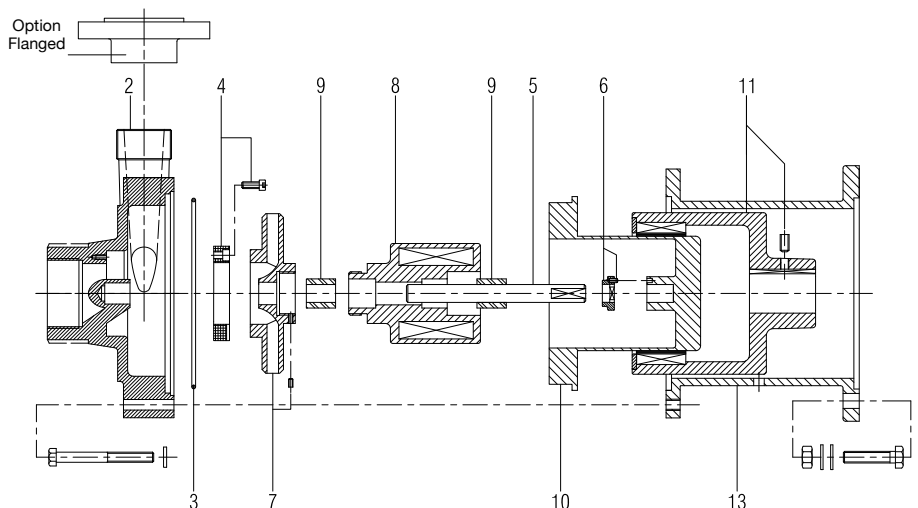



TURBINE PUMPS STM Series

STM regenerative turbine pumps are ideally suited for low flow / high head applications. All STM pumps are equipped with zero leakage magnetic couplings to meet the latest toxic emissions regulations. The absence of mechanical seals or packing glands eliminates costly pump maintenance, lost production time and process contamination.

STM turbine impellers are perfectly balanced with no residual axial load. Added reliability in even the most adverse operating conditions.

STM pumps are able to pump liquids containing up to 20% entrained gas, it is possible to feed two different liquids (or a liquid and a gas) simultaneously into the suction of the pump. The rotary motion of the impeller quickly and efficiently mixes the two substances together. The turbine impeller's strong stirring capability eliminates the need for using a static mixer or diffusion pipe. Dynamic design, can be throttled to a required duty point without by-passing. Heavy duty casing and impeller components, machined from wrought alloy bars. Rugged containment housing for added safety. Available in standard or API configurations.

FEATURES

- Single stage regenerative turbine pumps
- Performances and Dimensions: our standard PN 16
- Models: 1,5x6 up to 2,5x9
- Threaded nozzles, option Flanged
- Low Flow, High Head

MATERIALS

- Stainless Steel AISI 316L fully machined
- On request Incoloy 825 and Hastelloy C

APPLICATIONS

- Chemical plants
- Pharmaceutical
- Food processing
- Laboratories
- Transfer of solvents and alkalies
- Refrigerants

All pumps are manufactured in accordance with the current CE-Standard **** Explosion proof models according to ATEX directive, category II are also available. ****

Discharge nozzles	1/2" up to 1"	
Poles	2	4
Capacity [m ³ /h]	up to 10	up to 5
Head [m]	up to 80	up to 25
Max. Pressure (Bar)	16	
Max. Temper. (°C)	300	

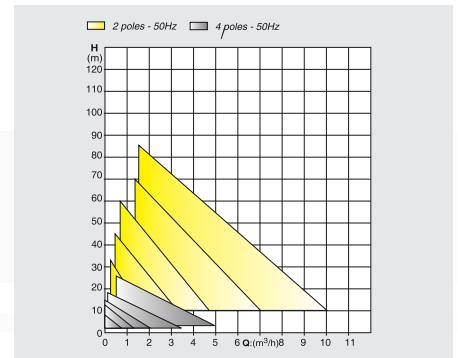

ref	DESCRIPTION	MATERIAL
10	Rear Casing	AISI 316L
20	Ext. Magnet	Neodym./Steel
30	Int. Magnet	AISI 316L/CoSm
40	Impeller	AISI 316L
51	O-Ring (a+b)	Viton
61	Thrust Bearings	PTFEC or Graphite AISI 316L
62	Rear Ring	AISI 316L
70	Shaft	AISI 316L or SIC
75	Sleeve Bearings	PTFEC or Graphite
78	Bracket	Cast Iron
84	Front Ring	AISI 316L
85	Pump Head	AISI 316L

SECTIONAL DRAWING

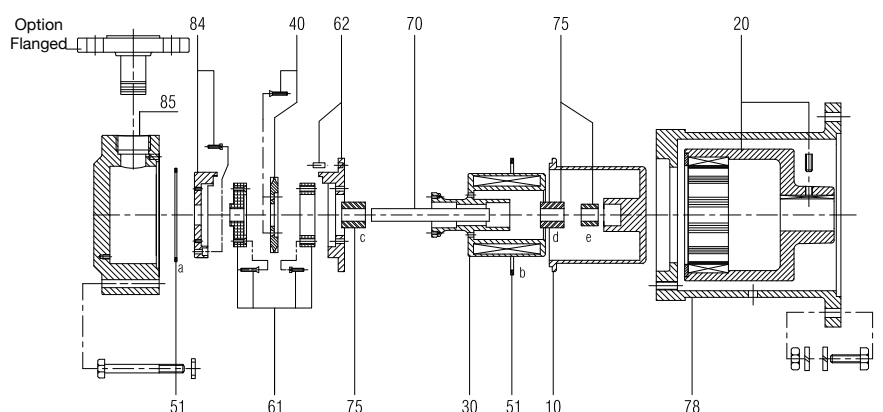

SPECIAL EXECUTIONS

SEAL-LESS VERTICAL PUMPS

NDMV Seal-less Vertical Pumps, ensure leak-proof handling of corrosives. The heavy duty shaft is supported by ball bearings without bushings to wear; shaft deflection is thereby eliminated

FEATURES

- Non-cantilevered shaft
- Hermetically sealed column
- Heavy duty column shaft with oversized ball bearings
- Modular impeller allows for modifying performances
- Compact, high torque magnetic coupling with reduced mass

MATERIALS OF COSTRUCTION AND PERFORMANCE SAME AS NDM ISO 2858 PUMPS.

PCMV Seal-less Vertical Pumps, ensure leak-proof handling of corrosives. The heavy duty shaft is supported by ball bearings without bushings to wear; shaft deflection is thereby eliminated.

PCMV Pumps are fabricated from solid thermoplastic material to resist internal or external corrosion. The hermetically sealed column is permanently isolated from corrosive liquid or fumes.

FEATURES

- Non-cantilevered shaft
- Hermetically sealed column
- Heavy duty column shaft with oversized ball bearings
- Exclusive solid machined thermoplastic casing and impeller components
- Oversized, high purity ceramic thrust bearings and shaft
- Modular impeller allows for modifying performances

MATERIALS OF COSTRUCTION AND PERFORMANCE SAME AS PCM PUMPS



SEAL-LESS API PUMPS

END SUCTION API 685 Seal-less Pumps, are designed to meet critical nozzle loading and working pressure requirements of API 685 standards.

FEATURES

- Over designed pump casings and baseplates
- Heavy duty containment housing for optimum safety
- External lubrication systems maintains highest pressure differential; allowing for deadheading and flow or pressure monitoring
- Dual back-pull-out (access hydraulic end or power frame)

SEAL-LESS MULTISTAGE BARREL API Pumps are built for reliable, leak-proof operation in high discharge head applications.

FEATURES

- Between bearings support with no overhung loads
- Staggered volutes minimize residual radial loads
- Dynamically balanced, back-to-back impellers for minimal axial load
- TOP-TOP Suction - Discharge
- Heavy duty barrel casing
- Working temperature up to 250 °C
- Flow up to 200 m³/h
- Head up to 500 m

